



ROCKCRETE
EQUIPMENT (PTY) LTD
Company Reg. No: 1947/024677/07

**OPERATORS MANUAL
FOR
ROCKCRETER 65**



SOUTH AFRICAN SHOTCRETE TECHNOLOGY
Designed to perform, the power to succeed!

P. O. Box 18924 Sunward Park 1470 • 361 Crocker Road, Wadeville, Germiston, South Africa
Co. Reg. no: 1947/24677/07

TEL: (+2711) 865 3019
e-mail: information@rockcrete.co.za
www.rockcrete.co.za

As part of our policy of constant product development and improvement information and specifications contained in this document are liable to change.

**OPERATORS MANUAL
FOR
ROCKCRETER 65**



Intentionally Left Blank

Intentionally Left Blank

1. SAFETY PROCEDURES

Recommended items to keep gunniting safe:

- a. Hard hats.
- b. Safety goggles.
- c. Dust masks in confined spaces or unventilated areas.
- d. Good lighting.
- e. Whip check cables and chain safety couplings on air supply hoses.
- f. Rubber gloves to protect workmen with skins sensitive to cement burns (also use barrier cream).
- g. Sturdy and safe lifting devices, platforms and scaffolding for those many gunning operations that are performed off the ground. All platforms should be equipped with safety rails.
- h. A qualified electrician must do all electrical connections.
- i. Do not remove the screen/sieve supplied on the hopper whilst the machine is in operation.
- j. Do not carry out any maintenance whilst the air or electrical connections are connected to the machine.
- k. Do not poke or prod any instrument of any sort into the hopper whilst the machine is in operation.

2. TECHNICAL SPECIFICATIONS

Height	1200 mm / with mixer 1400 mm
Width	800 mm
Length	1400 mm
Weight	680kg
Output	Up to 4 Cubes / hr
Drive	Drive 380 V / 525 V / Air
Options	Variable Electric / Air Motor / Diesel
Air Required for Electric	4 - 6 bar @ 450 c.f.m.
Air Required for Air	4 - 6 bar @ 750 c.f.m.
Conveying Distance	Up to 200 m (with mods)

3. PRINCIPLES OF OPERATION

- a. Sand aggregates and cement are first mixed thoroughly and then fed into the machine hopper.
- b. The mix is gravity fed down the hopper into the rotor which has several chambers and is sealed by two rubber wear pads and two wear plates.
- c. As the rotor rotates, air is introduced which discharges the mix down through the outlet bend underneath the rotor.
- d. The discharge spout has a special reinforced hose connected to it. The material is now transported by a stream of air to the nozzle.
- e. At the end of the hose is the nozzle with a water connection and a water injection system.
- f. The nozzle operator adjusts the tap and injects the correct amount of water into the stream of material.
- g. The nozzle operator now places the material on to the working surface as required.

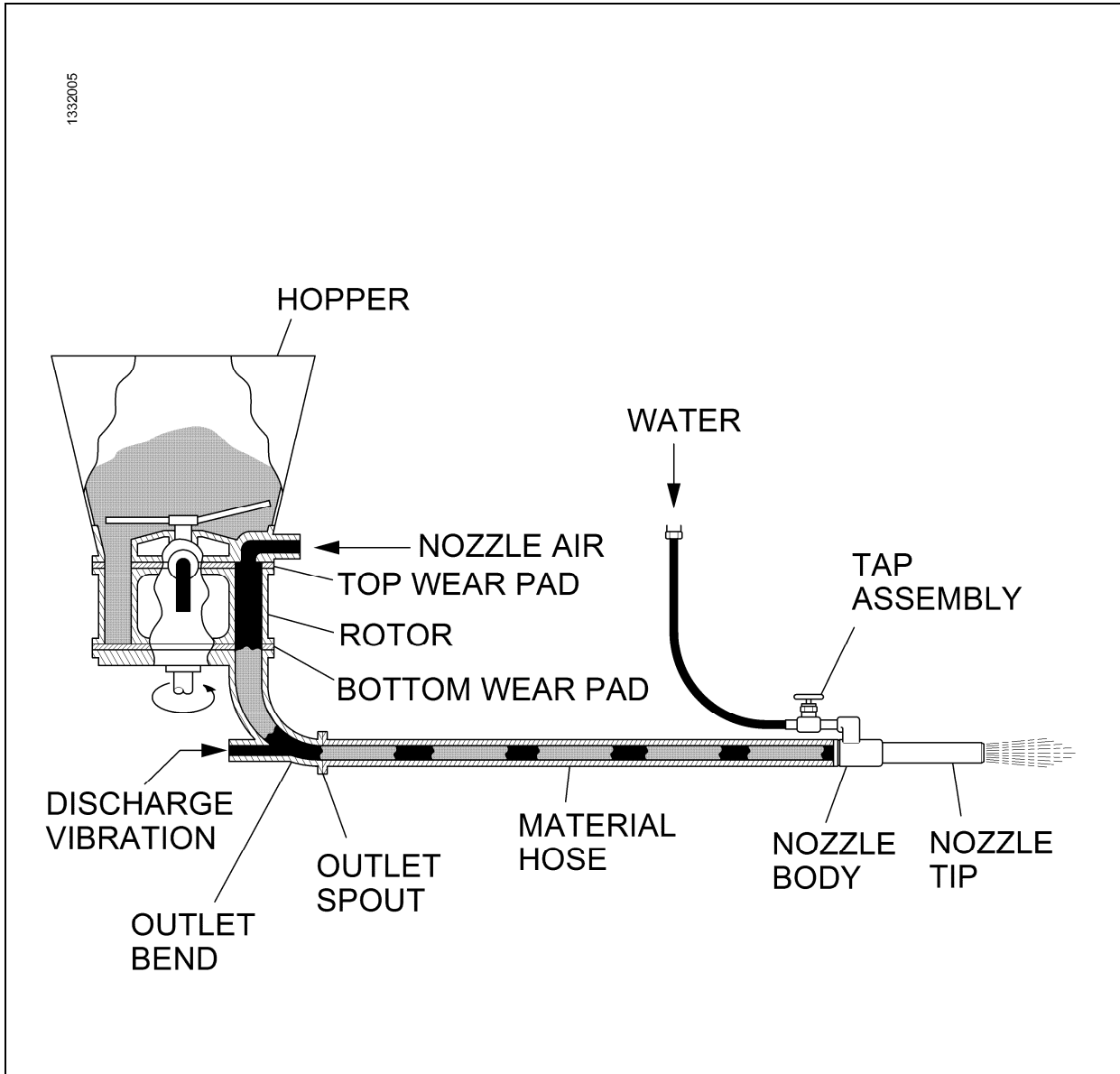
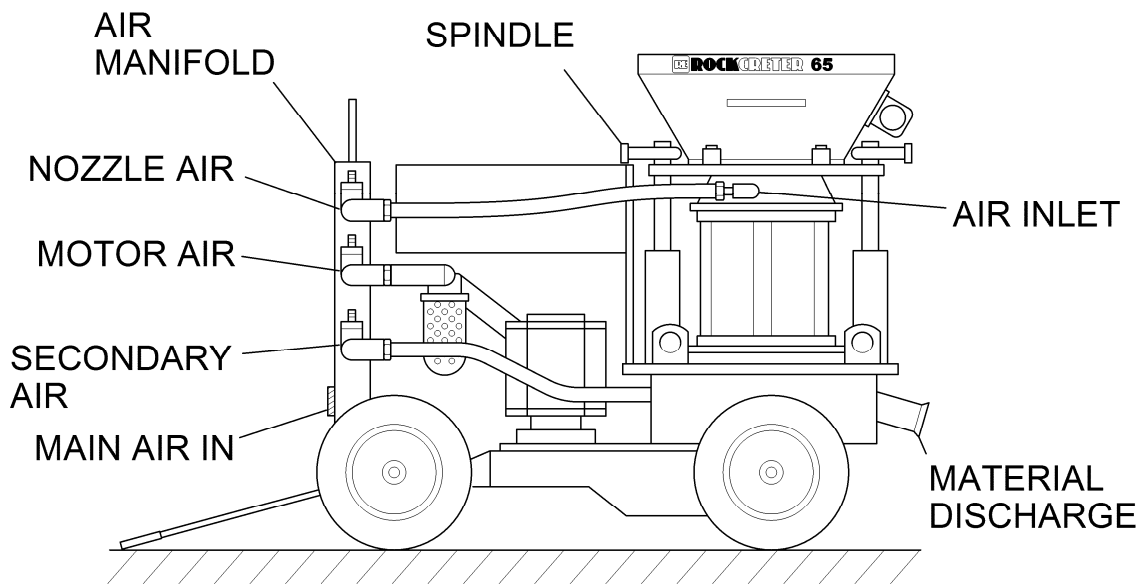

Figure 1

1332004



RE ROCKCRETER 65

Figure 2

4. OPERATING PROCEDURES

IMPORTANT

MAKE SURE THAT THE AGGREGATES HAVE A MOISTURE CONTENT OF AT LEAST 5% PRIOR TO MIXING THE CEMENT. THIS WILL REDUCE DUST AT THE NOZZLE AND REBOUND AT THE WORKING FACE.

4.1 Machine Setting

1. First hand-tighten the two spindles on the air inlet side.
2. Tighten the other spindle to the same tension to ensure the clamping is even.
3. The first two spindles can be adjusted slightly more as this is where most pressure takes place.

4.2 Starting Up Procedure

1. Open the air valve to the nozzle and check air supply with nozzle operator.
2. Open water tap at nozzle and check for water supply.
3. Fill the hopper with material.
4. Open the valve to the air motor/switch on electric motor.

NOTE

All gunite/shotcrete machine rotors turn anti-clockwise.

4.3 Shutting Down Procedure

1. Allow hopper to empty of all material.
 2. Close air valve to motor or switch off to stop the rotor.
 3. Allow material hose to clear.
 4. Close the water tap at the nozzle.
 5. Close air valve to nozzle after all materials are cleared out of hose.
-

4.4 Checking Output

To attain the maximum output for the machine the rotor must run at the correct speed. The output may vary with different materials. The rotation speed must allow the chambers to fill completely while giving an even flow at the nozzle. This will enable the operator to achieve the maximum output at the lowest running cost.

5. MAINTENANCE PROCEDURES

5.1 Daily Maintenance Routine

It is important to appoint a member of the gunite crew who is solely responsible for the maintenance and operation of the gunite/shotcrete machine. The machine operator should liaise with the nozzle operator as to what speed the machine runs at to control the output and also to regulate the airflow to the nozzle operator. This will regulate the daily production and control waste due to rebound.

REMEMBER

DUE TO THE FACT THAT THE MACHINE OPERATES WITH SAND AND CEMENT, WHICH MAY VARY IN MOISTURE CONTENT, THE MACHINE MUST BE CLEANED AFTER EACH SHIFT OR IF LONG STOPPAGES OCCUR.

5.2 Cleaning Procedure

1. Before switching off the machine, let the hopper empty and blow the delivery hoses clear.
2. Disconnect power and/or air to the motor.
3. Strip the machine, clear loose material and remove any build-up which has occurred.
4. Inspect wearing parts such as top and bottom wear pads and wear plates for uneven or excessive wear.

REMEMBER

IT IS NOT ADVISABLE TO REPLACE A WORN PAD AND NOT THE MATCHING WEAR PLATE AS THIS WILL RESULT IN THE PAD WEARING MUCH QUICKER. (CHANGE AS SET).

5. Once the machine has been properly cleaned and re-assembled, it is good practice to apply grease to the pads to prevent binding when the machine is restarted (red rubber grease is recommended).
6. Remove the nozzle tip and inspect the water ring to see if the holes are clear, apply grease and replace. The machine is now ready for the next operation.

IMPORTANT

LIAISE WITH YOUR MANUFACTURER OR SUPPLIER AS TO WHICH OILS SHOULD BE USED IN THE LUBRICATOR FOR THE AIR MOTOR.

5.3 Hoses

Only use hoses recommended by your supplier. To obtain the best results observe the following.

1. Always use a sieve on your machine to avoid blockages.
 2. Avoid sharp bends when using hoses.
 3. Fit couplings flush with end of hoses.
 4. Do not use badly worn hoses. This can be dangerous.
-

6. TROUBLE SHOOTING

FAULTS	POSSIBLE CAUSE
Excessive rebound.	<ul style="list-style-type: none"> a. Sand too dry or wrong grading. b. Poor water pressure at nozzle or blocked water ring. c. Machine not set correctly. d. Nozzle man not applying correctly.
Machine blowing excessively.	<ul style="list-style-type: none"> a. Machine not set correctly. b. Plates or pads need replacing. c. Blockage in system. d. Speed is set incorrectly
Uneven running.	<ul style="list-style-type: none"> a. Pad clamped too tight. b. Material between plates and pads. c. Bent main shaft.
Insufficient output.	<ul style="list-style-type: none"> a. Moisture of sand too high. b. Poor air supply. c. Blockage in system. d. Machine not set correctly.
Surging at the nozzle.	<ul style="list-style-type: none"> a. Machine running at incorrect speed. b. Moisture content of sand too high. c. Blockage in system.
Rotor running too slowly.	<ul style="list-style-type: none"> a. Poor air supply. b. Exhaust blocked. c. Machine clamped too tight. d. Motor not lubricated or vanes worn. e. Strainer cage is blocked

NOTE

Should you experience any other problems contact your supplier.

ROCKCRETER 65 – PRE USE CHECK LIST

Checked by: _____
Date: _____
Time: _____
Section: _____
Comments: _____

**WARNING: REPORT DAMAGE, DEFECTS
OR FAULTY OPERATION IMMEDIATELY.
DO NOT OPERATE ROCKCRETE PUMP UNTIL
CORRECTED**

Checked and in order

Checked and found defective

SAFETY PRECAUTIONS

1. Isolate all air & electric's during inspection and maintenance.
2. Keep hands away from moving parts.
3. Wear all necessary safety gear.

BEFORE STARTING THE ROCKCRETER 65

1. Check that air and water pressure is sufficient.
2. Check all air, electrical & water connections are in safe working order.
3. Check top and bottom wear pads and wear plates, if worn, replace.
4. Check discharge bend, liner and discharge spout and liner, if worn, replace.
5. Check rotor and hoses for any material or blockages before turning on the air valve.
6. Check and make sure the sieve is in place and secure.
7. Check nozzle tip water ring for blockages, if blocked clean. Check O-rings, apply grease on O-rings.
8. Check oil in lubricator. (SAE 30 Grade).
9. Check clamps & gaskets are in place and secure to all fittings

AFTER STARTING THE ROCKCRETER 65

10. Check rotation of rotor-- anti clockwise
11. Check smooth operation of ROCKCRETER 65

NOTE: ALWAYS KEEP ENOUGH WATER ON SITE OF CLEANING

ROCKCRETER 65

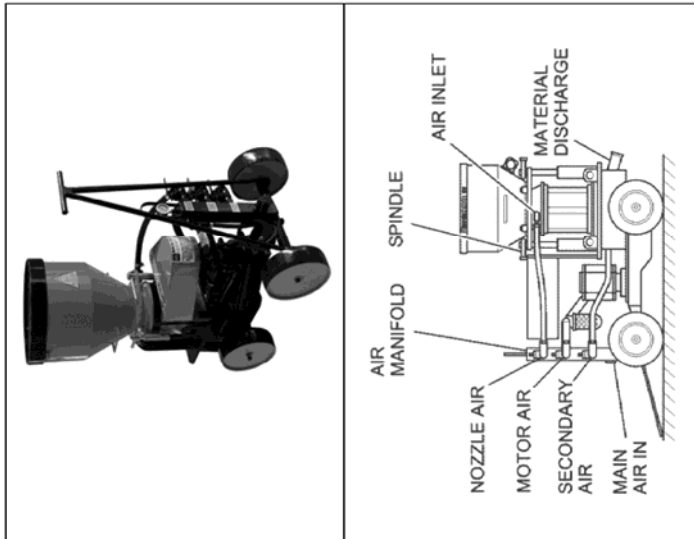

CHECK	GO	NO GO
1		
2		
3		
4		
5		
6		
7		
8		
9		

10		
11		

Intentionally Left Blank

1. BODY ASSEMBLY

ITEM NO	DESCRIPTION	PART NO	QTY	COMMENTS
1	SIEVE	EA001	1	
2	AGITATOR SPIDER	EA012A	1	
3	GASKET, AGITATOR SPIDER	EA013	1	
4	HOPPER	D001	1	
5	RING, TOP CASTING	D005	1	
6	TOP CASTING	D004/A	1	
7	ROTOR ASSEMBLY		1	SEE PAGE 17
8	CLAMP, SPINDLE	D003	3	
9	BASE	D011	1	
10	OUTLET CLAMP	D018	1	
11	PIVOT BOLT	D019A	2	
12	TEE SCREW	EA014	1	
13	BEND, DISCHARGE	D014	1	
14	LINER, BEND, DISCHARGE	D015	1	
15	SPOUT, DISCHARGE	D016	1	
16	LINER, SPOUT, DISCHARGE	D017	1	
17	COVER, MOTOR	D024	1	
18	GEARBOX ASSEMBLY	IGH99	1	SEE PAGE 23
19	WHEEL, HEAVY DUTY	EA006/A	4	
20	AXLE, REAR	EA017	2	

1. BODY ASSEMBLY (CONTINUED)

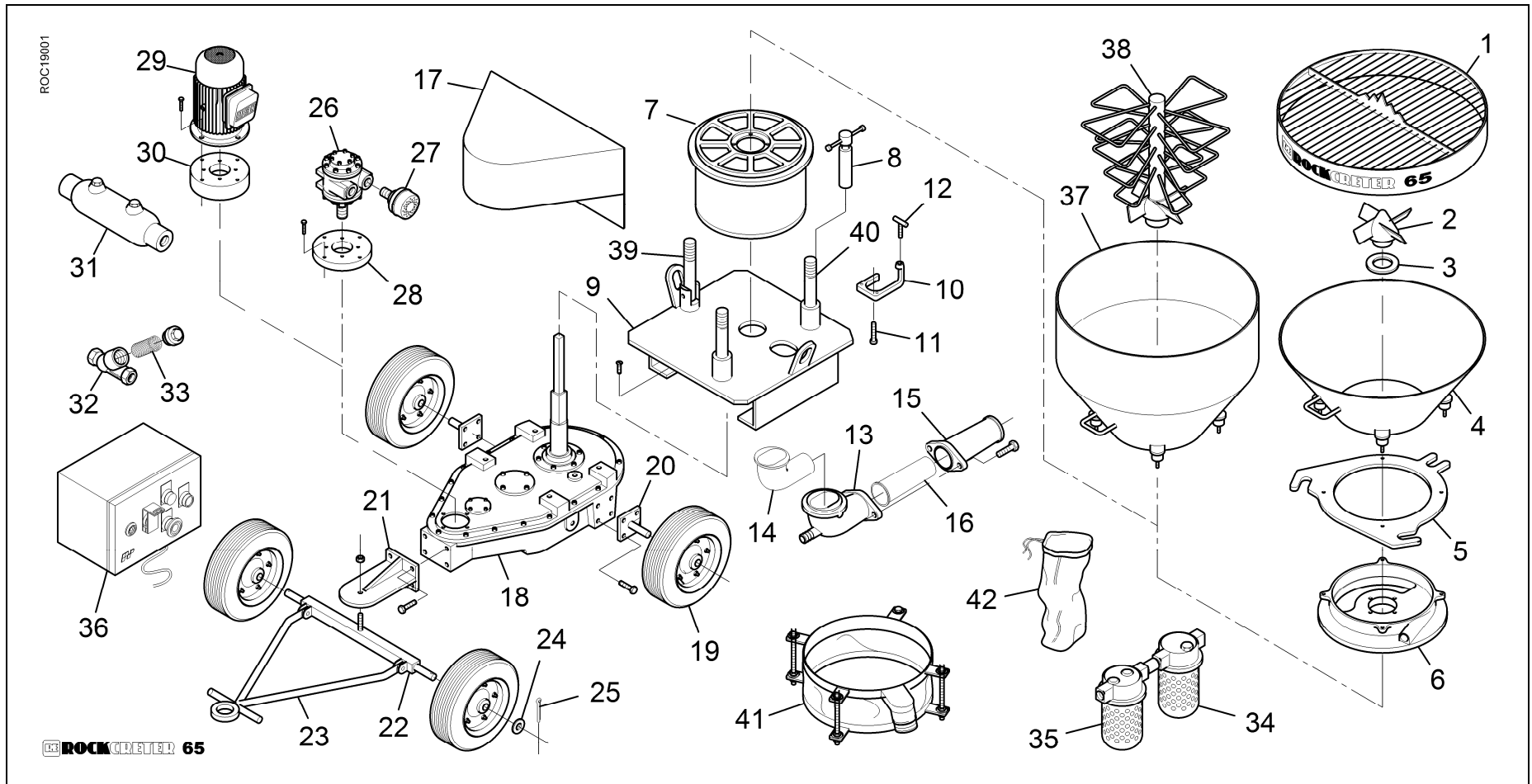

1. BODY ASSEMBLY

ITEM NO	DESCRIPTION	PART NO	QTY	COMMENTS
21	BRACKET, AXLE	EA008	1	
22	AXLE, FRONT	EA018	1	
23	HANDLE, VEE	EA011	1	
24	WASHER, FLAT	BW30	4	
25	PIN, SPLIT	BP05	4	
26	MOTOR ASSEMBLY, AIR, 10HP	RC10	1	SEE PAGE 19
27	MUFFLER, AIR MOTOR	EA002	1	
28	FLANGE, AIR MOTOR	IGH23	1	
29	MOTOR, ELECTRIC	EA027/28	1	
30	FLANGE, ELECTRIC MOTOR	EA032	1	
31	LUBRICATOR, CYLINDER TYPE	EA005	1	
32	DIRT TRAP	EA007	1	
33	DIRT TRAP FILTER	EA007A	1	
34	WATER TRAP	EA003	1	
35	LUBRICATOR, BOWL TYPE	EA004	1	
36	525 V CONTROL PANEL	EA037	1	
37	MIXING HOPPER	D002/A	1	
38	MIXING ELEMENT	D002M	1	
39	SWIVEL ARM	D032	1	
40	SOLID SUPPORT	D012	2	

1. BODY ASSEMBLY (CONTINUED)

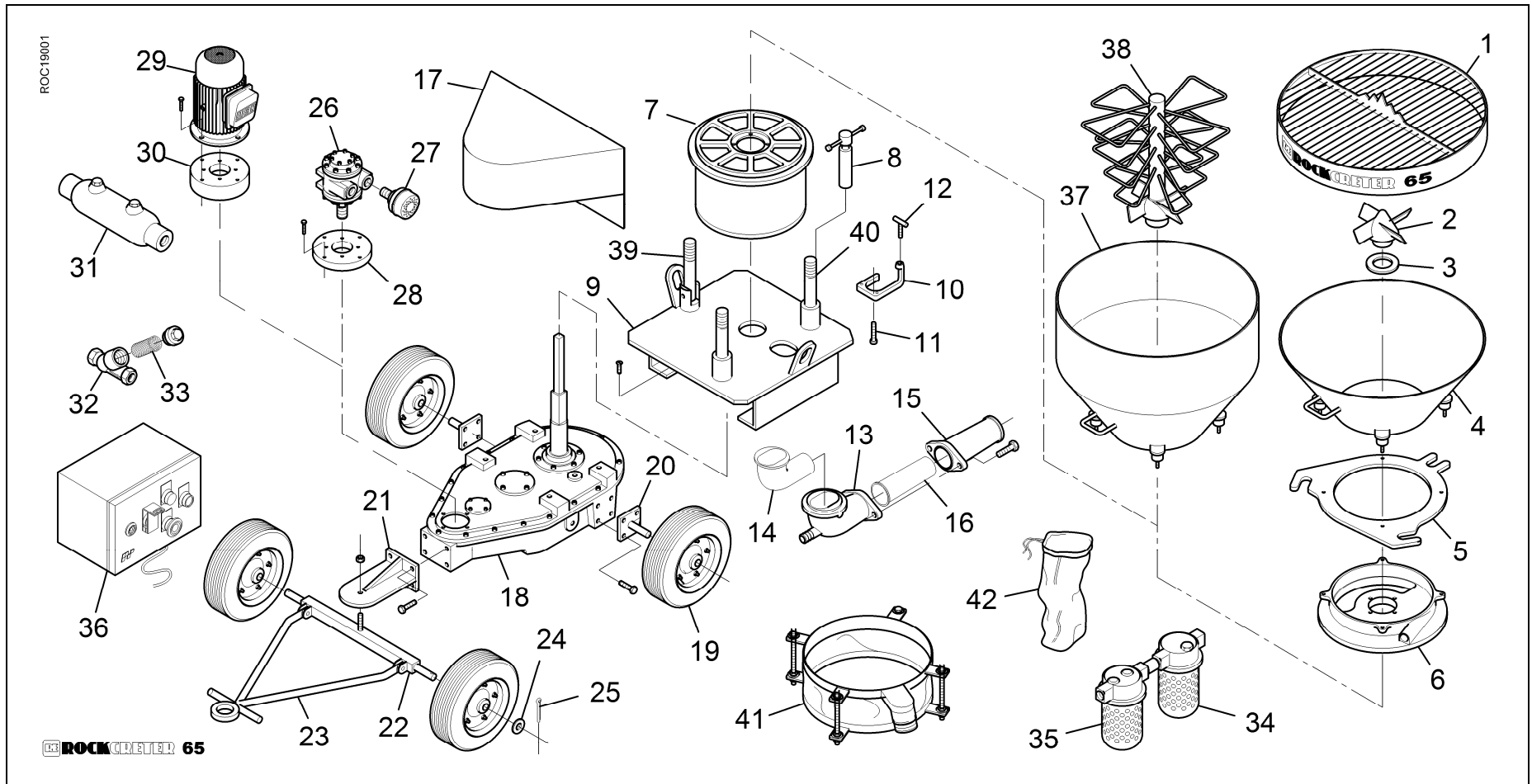

2. ROTOR ASSEMBLY

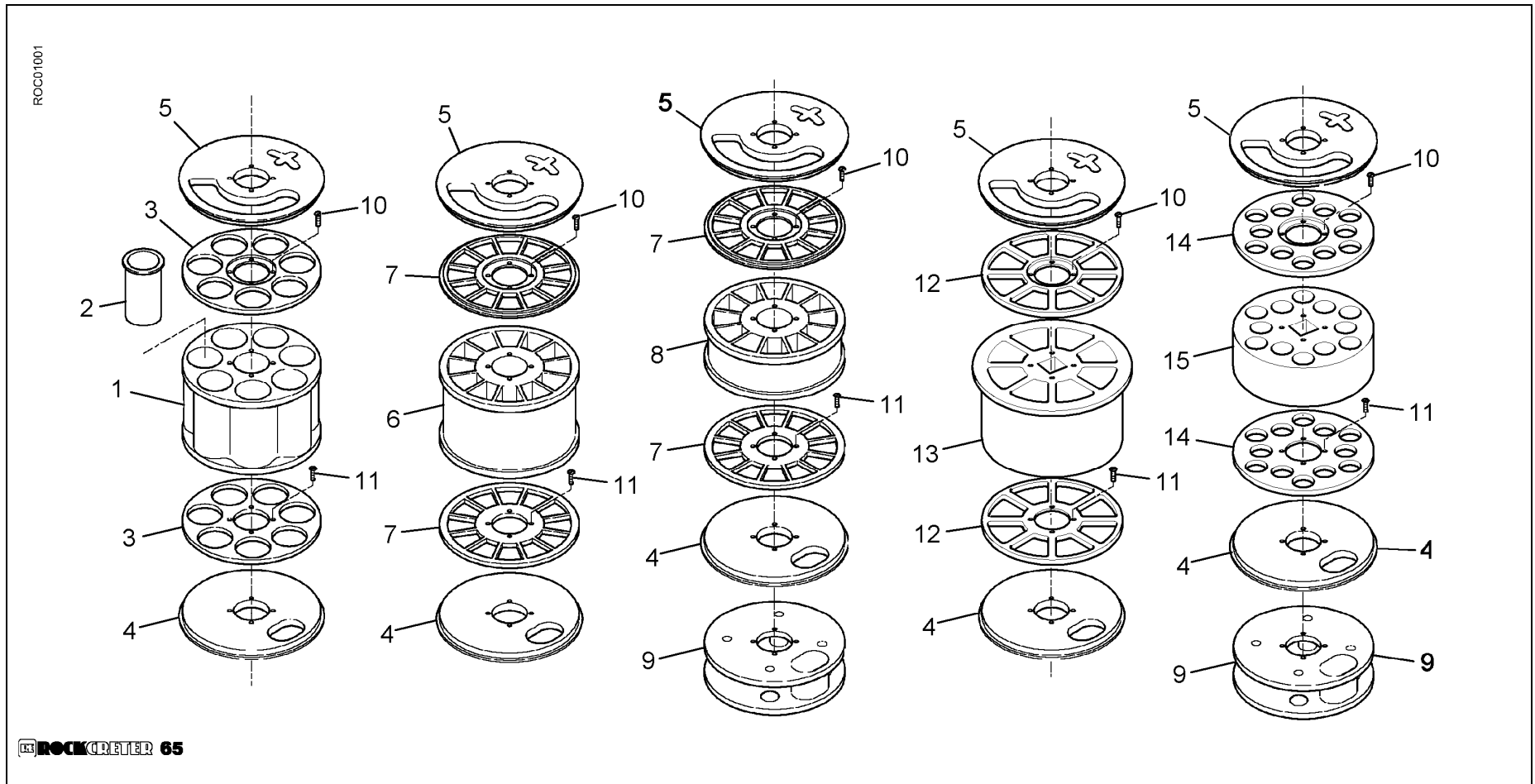

2. ROTOR ASSEMBLY

ITEM NO	DESCRIPTION	PART NO	QTY	COMMENTS
1	ROTOR, ROUND HOLE	D007	1	
2	LINER, ROTOR	D008	7	
3	WEAR PLATE, ROUND HOLE	D006	2	
4	WEAR PAD, BOTTOM	D010	1	
5	WEAR PAD, TOP	D009	1	
6	ROTOR, SQUARE SECTOR	D007S	1	
7	WEAR PLATE, SQUARE SECTOR	D006S	2	
8	ROTOR, HALF SQUARE SECTOR	D007SE	1	
9	SPACER	D053	1	
10	WEAR PLATE SCREW	BC11	BOX 100	
11	WEAR PAD SCREW	BS10	BOX 100	
12	8 HOLE WEAR PLATE	D006X	2	
13	X-ROTOR	D007X	1	
14	12 HOLE ROUND HOLE WEAR PLATE	D006E	2	
15	12 ROUND HOLE ROTOR	D007E	1	

3. 10 HP AIR MOTOR ASSEMBLY

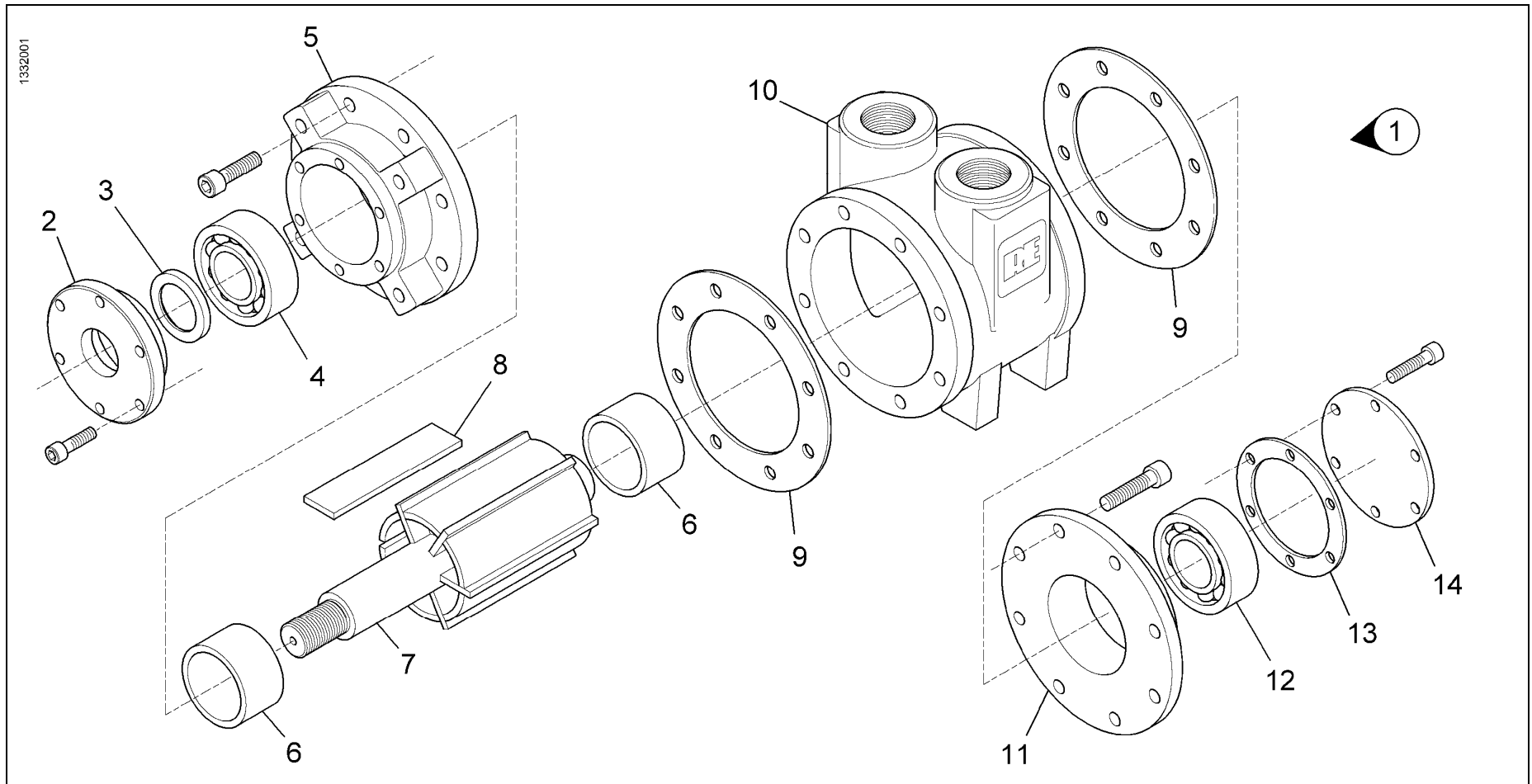

3. 10 HP AIR MOTOR ASSEMBLY

ITEM NO	DESCRIPTION	PART NO	QTY	COMMENTS
1	ROCKCRETER 10 HP AIR MOTOR	RC10	1	
2	COVER, FRONT, BEARING	RC02	1	
3	OIL SEAL	RC01	1	Supplied in Repair Kit
4	BEARING, FRONT	RC03	1	Supplied in Repair Kit
5	COVER, FRONT, MOTOR	RC11	1	
6	RING	RC09	2	
7	ROTOR	RC07	1	
8	VANE	RC05	6	Supplied in Repair Kit
9	GASKET	RC06	2	Supplied in Repair Kit
10	MOTOR HOUSING	RC12	1	
11	COVER, REAR, MOTOR	RC13	1	
12	BEARING, REAR	RC04	1	Supplied in Repair Kit
13	GASKET	RC06	1	Supplied in Repair Kit
14	COVER, REAR, BEARING	RC14	1	
15	REPAIR KIT	RC00	1	RC01, 03, 05, 06, 04

4. HOSE ASSEMBLY

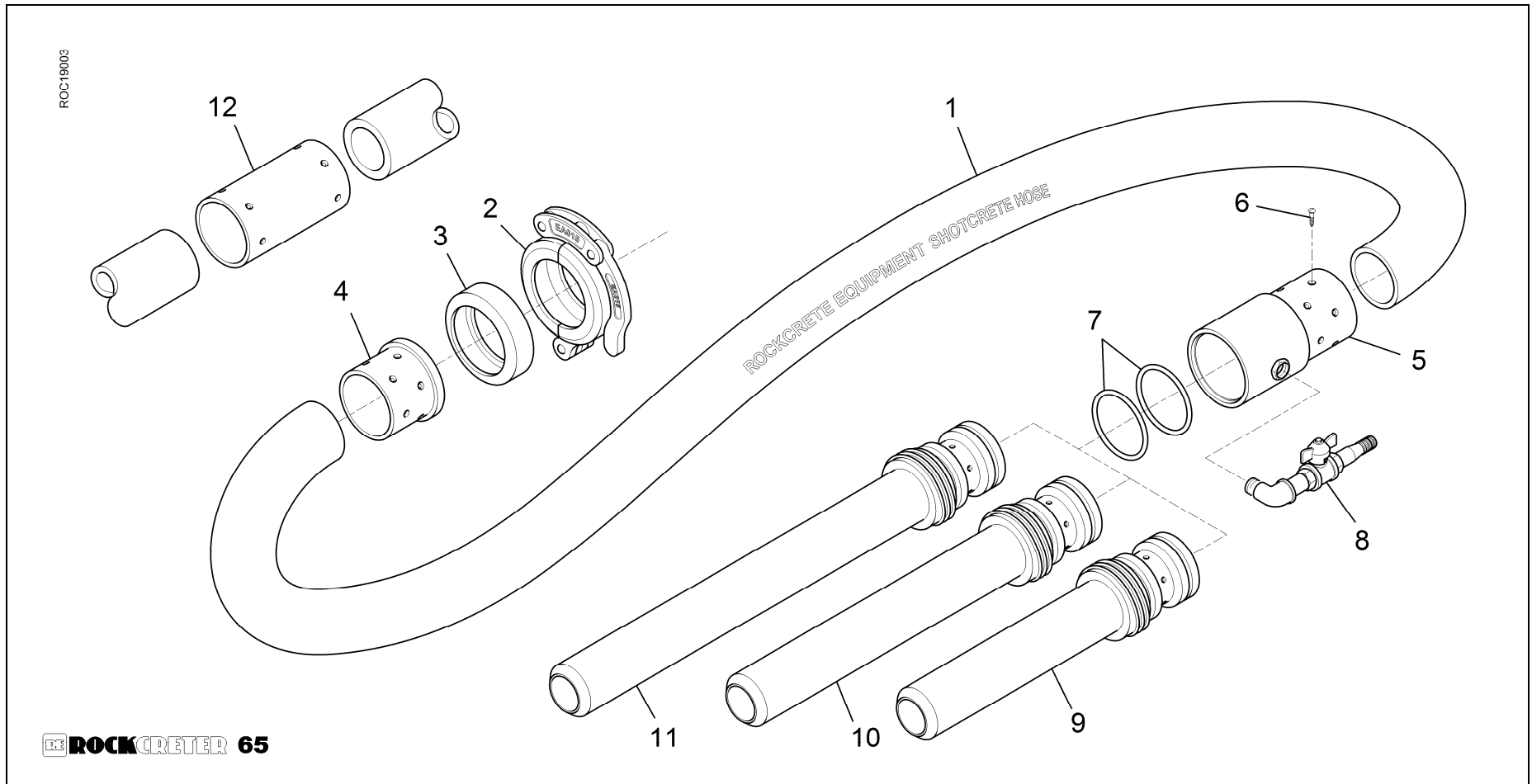

4. HOSE ASSEMBLY

ITEM NO	DESCRIPTION	PART NO	QTY	COMMENTS
1	HOSE, 30 M X 50 X 74 MM	E001-30	1	
2	COUPLING, CARBOUFER	EA015	1	
3	GASKET, CARBOUFER	EA016	1	
4	COUPLING, SHOULDER	E016	1	
5	NOZZLE BODY COMPLETE, WITH TAP	E012	1	WITH TAP ASSEMBLY
6	SCREW, SELF TAPPING	BS13	BOX 100	
7	O-RING	E010	2	
8	TAP, WATER ASSEMBLY	E013	1	
9	SWIMMING POOL NOZZLE	E008S	1	
10	TIP, STANDARD NOZZLE C/W O-RINGS	E008	1	
11	TIP 1,5 M NOZZLE C/W O-RINGS	E009	1	
12	HOSE MENDER	E021	1	
13	30M COMPLETE HOSE UNIT STD NOZZLE	E005-30	1	E001-30,E008, E010, E012, E016
14	HOSE WITH COUPLINGS ONLY	E003	1	E001, E016

5. HOSE ASSEMBLY

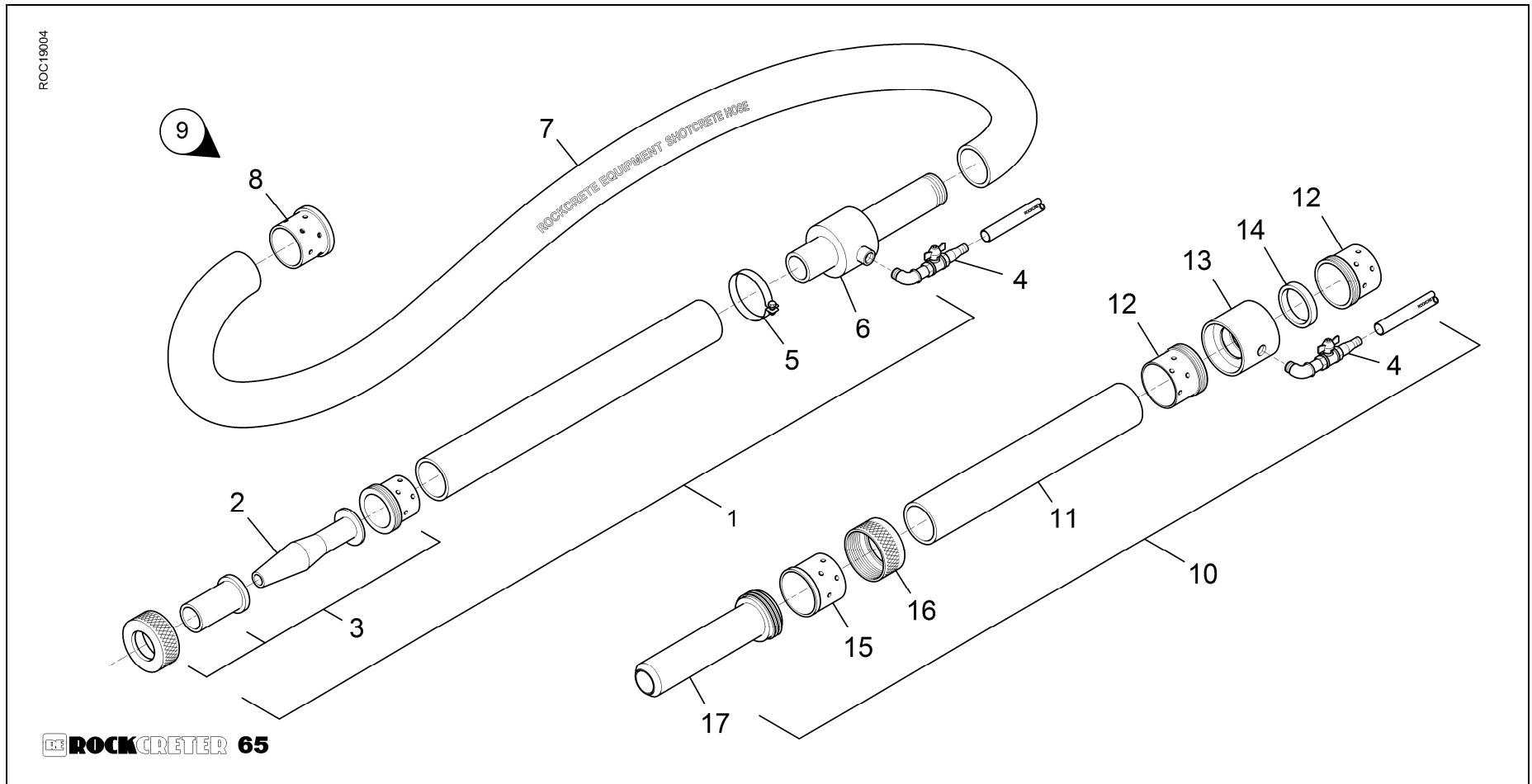

5. HOSE ASSEMBLY

ITEM NO	DESCRIPTION	PART NO	QTY	COMMENTS
1	REFRACTORY NOZZEL ASSEMBLY	E036	1	
2	REFRACTORY NOZZEL	E035	1	
3	FOUNDRY COUPLING SET	E032	1	
4	TAP, WATER ASSEMBLY	E013	1	
5	CLAMP	E033B	1	
6	38MM WATER MIXER	E033	1	
7	30M X 38MM ROCKCRETER MATERIAL HOSE	E019A	1	
8	COUPLING, SHOULDER	E016E	1	
9	30M X 38MM COMPLETE HOSE AND REF NOZZLE	E019C-30	1	
10	38MM PREMIX NOZZLE SYSTEM	E040	1	
11	600MM X 38MM HOSE	E019B	1	
12	38MM THREADED COUPLING	E028	2	
13	39MM NOZZLE BODY	E027	1	
14	38MM BRASS WATER RING	E026	1	
15	COUPLING, SHOULDER	E029	1	
16	38MM COUPLING NUT	E030	1	
17	38MM NOZZLE TIP	E031	1	

6. HOSE ASSEMBLY

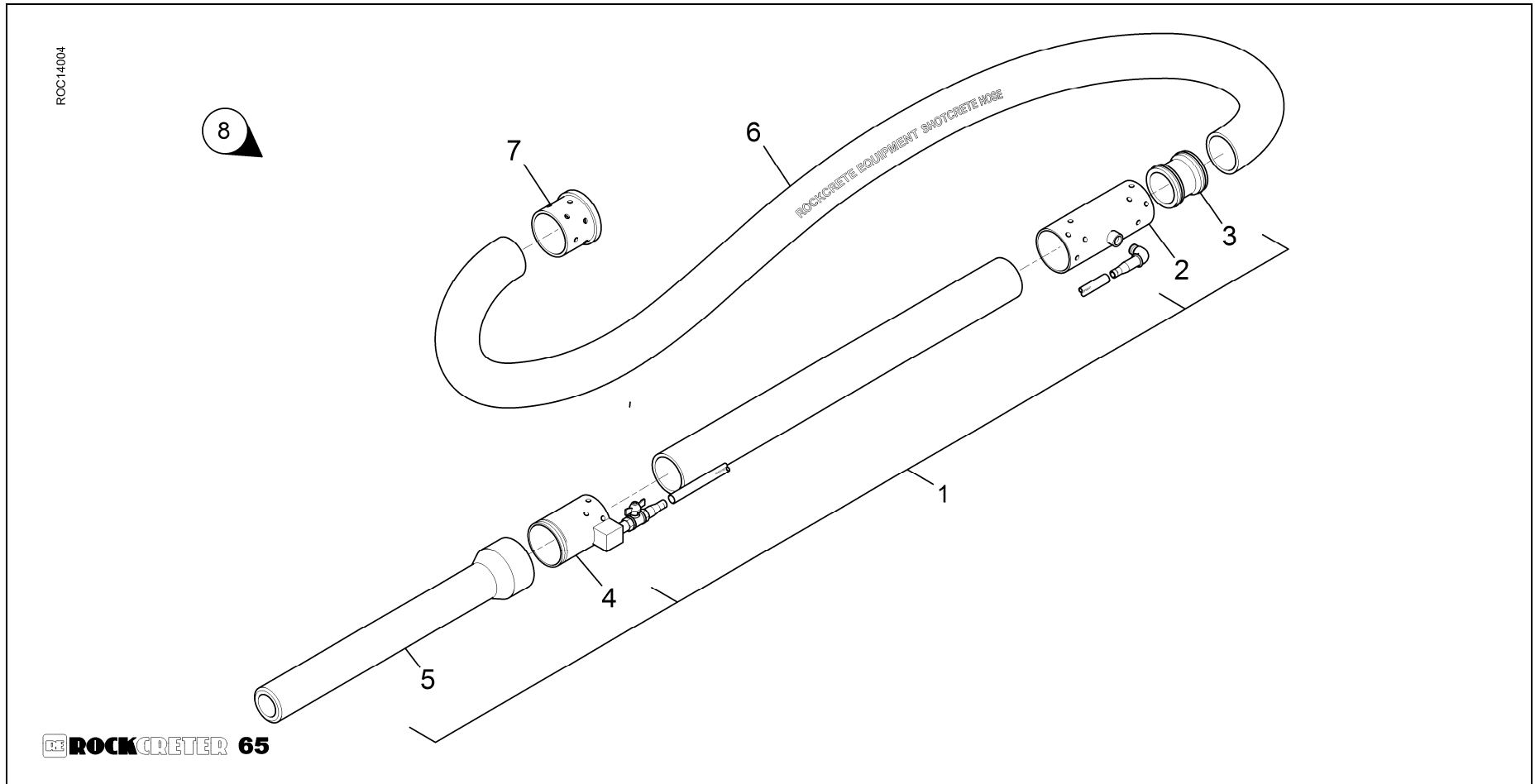

7. GEARBOX ASSEMBLY

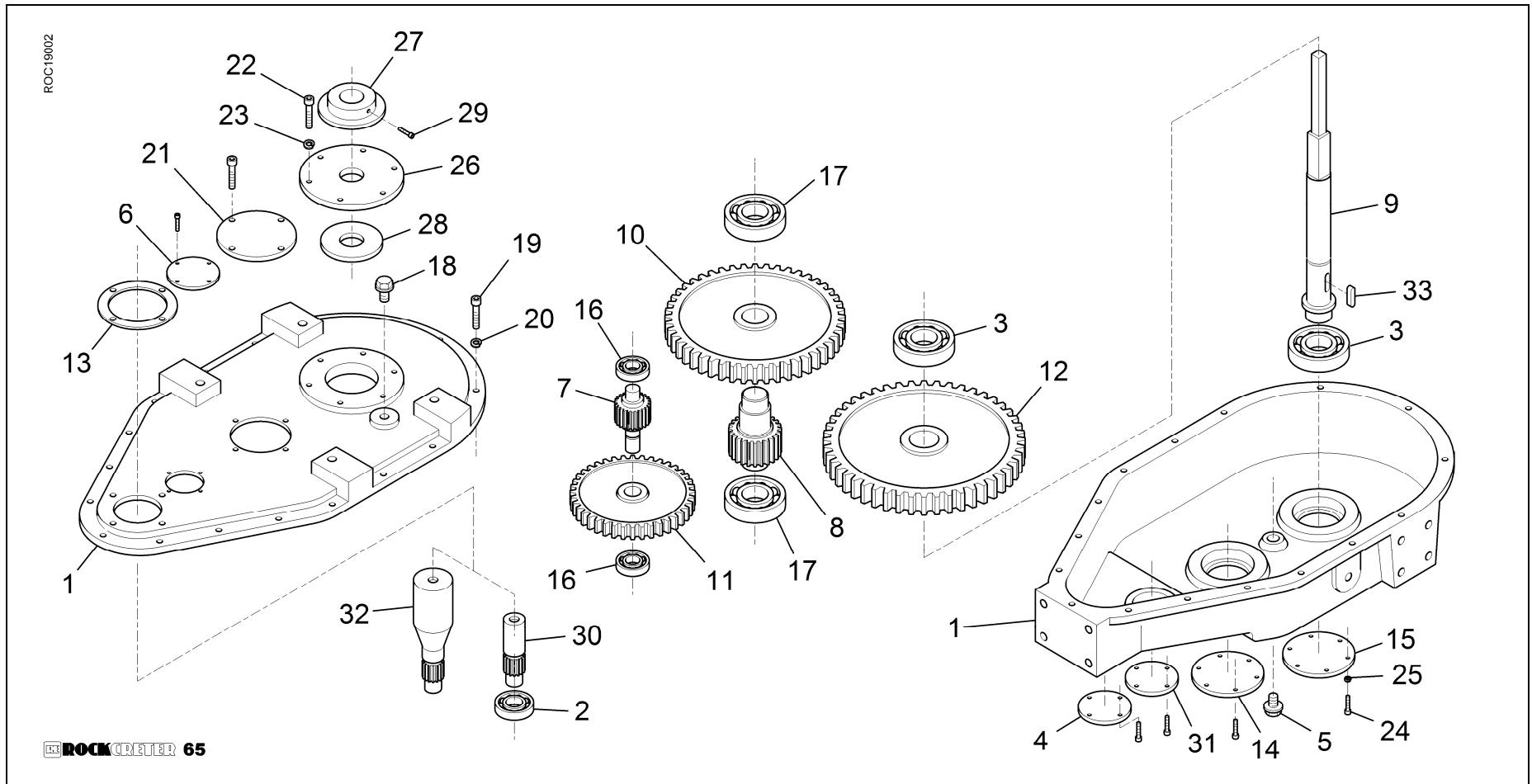

7. GEARBOX ASSEMBLY

ITEM NO	DESCRIPTION	PART NO	QTY	COMMENTS
1	HOUSING, GEARBOX	IGH01/02	1	
2	BEARING	IGH34	1	
3	BEARING	IGH33	2	
4	COVER, 90 MM BEARING	IGH08	1	
5	PLUG	ISH45	1	
6	COVER, 80 MM BEARING (SHORT LIP)	IGH06	1	
7	GEAR, 51 MM	IGH16	1	
8	GEAR, 80 MM	IGH15	1	
9	SHAFT, MAIN	D021	1	
10	GEAR, 280 MM	IGH13	1	
11	GEAR, 185 MM	IGH14	1	
12	GEAR, 310 MM	IGH12	1	
13	SEAL, OIL	IGH11A	1	
14	COVER, 119 MM BEARING	IGH05	1	
15	COVER, 150 MM BEARING	IGH04	1	
16	BEARING	IGH31	2	
17	BEARING	IGH32	2	
18	PLUG, BREATHER	IGH45	1	
19	SCREW, CAP	BC12	16	
20	WASHER, SPRING	BW02	16	

7. GEARBOX ASSEMBLY (CONTINUED)

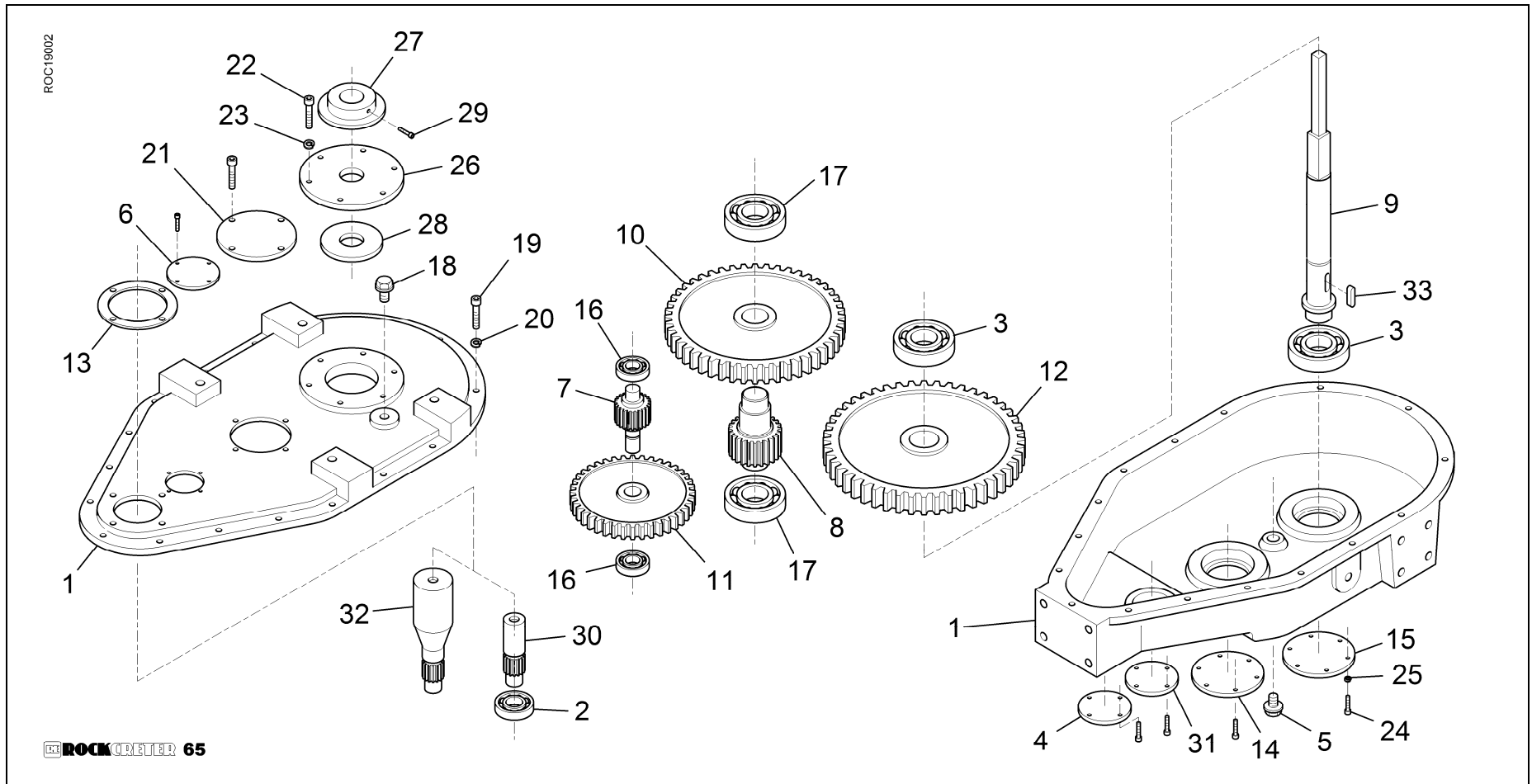

7. GEARBOX ASSEMBLY

ITEM NO	DESCRIPTION	PART NO	QTY	COMMENTS
21	COVER, 119 MM BEARING	IGH05	1	
22	SCREW, CAP	BC05	6	
23	WASHER, SPRING	BW01	6	
24	SCREW, CAP	BC10	6	
25	WASHER, SPRING	BW02	6	
26	FLANGE, SHAFT	IGH03	1	
27	COVER, DUST	IGH09	1	
28	SEAL, OIL	IGH11	1	
29	SCREW, GRUB	BG01	1	
30	GEAR, 34 MM PINION FOR AIR MOTOR	IGH20	1	
31	COVER, 80 MM BEARING (LONG LIP)	IGH07	1	
32	GEAR, 28 MM PINION FOR ELECTRIC MOTOR	IGH18	1	
33	MAIN SHAFT KEY		1	

